

Smart Management Modules (SMM)

GENERAC® LOAD MANAGEMENT

Model: G007006-0
UPC: 696471077520



FEATURES

Generac's Smart Power Management System is designed to optimize the performance of a standby generator. The system can consist of up to 8 individual Smart Management Modules (SMM). Unlike other load management systems that depend on another control device, the SMM modules are actually self-aware and operate autonomously.

Frequency is the true measure of generator engine performance, and does not need to factor in increased ambient temperatures, elevation changes, or generator fuel type. The modules monitor the frequency (Hz) of the power being produced by Generac's standby generators. If frequency falls below a certain threshold of a correctly sized system, the module will automatically shed the managed loads to allow the generator to recover.

The modules can be set to a load priority between 1-8 or be set in a lock-out only mode for loads that just simply do not need to run in an outage, therefore reducing the necessary size of the generator for a more cost-effective solution*.

* It is recommended to size the generator with appropriate excess capacity to allow starting of the largest managed loads (i.e. loads with highest starting currents). Each managed load of the SACM and SMM must be assigned a unique priority setting, so no two managed loads attempt to start simultaneously. See owners manual for more information.

SMM SPECIFICATIONS

Power supply source	240 VAC (from Line input)
Contact voltages.....	220/240 VAC
Contact coil voltage.....	240 VAC
Coil VA inrush.....	300
Coil VA sealed.....	35
Poles	2
Resistive amps	100
F/L inductive amps	90
Locked rotor amps.....	540
NEMA	3R
Enclosure rating	UL 50
Frequency selectability	50 Hz / 60 Hz
Wire gauge range box lugs	1/0 to 8 AWG
Wire material.....	Cu
Coil pick up voltage.....	80%
Coil drop out voltage.....	20%
Maximum contact voltage.....	600VAC
Ambient temperature maximum	149 °F (65 °C)
Coil terminals.....	18 AWG

Smart Management Modules (SMM)**Dimensions and UPC****Dimensions and UPC**

Model		G007006-0
Height (in/mm)	H1	7.0 / 178.5
	H2	2.4 / 61
Width (in/mm)	W1	11.39 / 289.4
	W2	7.8 / 200
Depth (in/mm)		5.3 / 136.9
Weight (lb/kg)		5.3 / 2.4
Shipping Weight (lb/kg)		5.8 / 3.62
UPC		696471077520

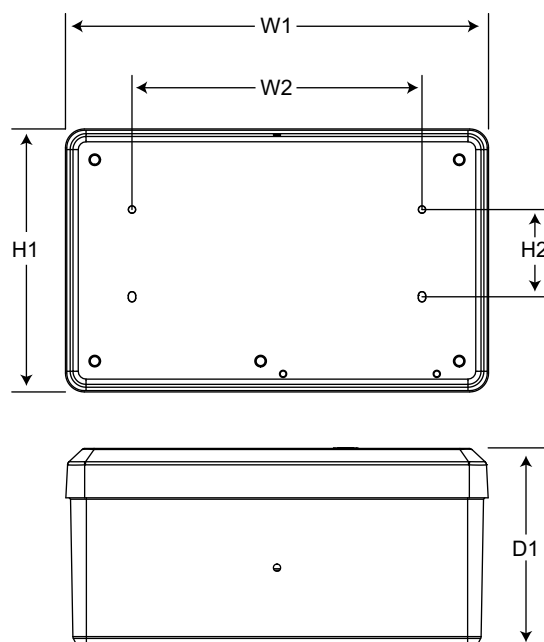
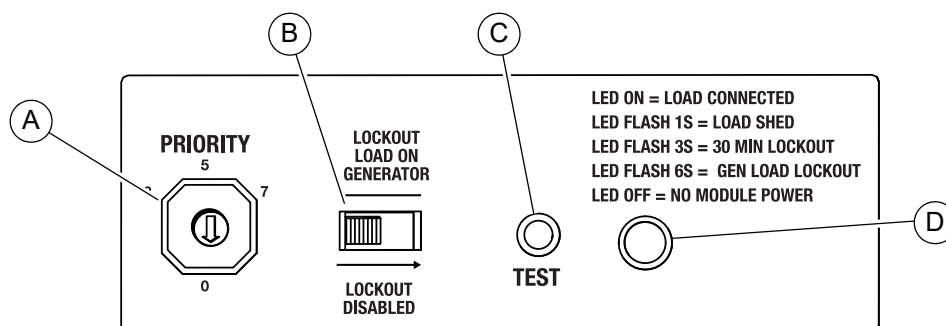
**SMM Controls (located behind the module cover)**

- Priority Dial (A)** Sets module priority
- Lockout Switch (B)** Prevents load from operating when system is operating under generator power.
- Test Button (C)** Disables contactor output for a specified time.
- LED (D)** Provides module status with easy viewing through the external viewing window located in the upper right corner of the module.