



H08051

Hybrid Series



Running/Starting Watts: 7250/9050

Running/Starting Watts: 8000/10000

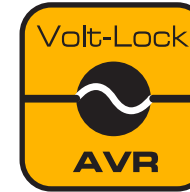

Features & Benefits

- Runs on gasoline or propane fuel, giving you flexibility while out on the road or during an emergency.
- Extended propane regulator/hose (5.5ft) for convenience when running off of a larger propane tank.
- The FIRMAN OHV engine (Max-Pro Series) for longer life/higher performance/lower maintenance.
- FIRMAN newly designed AVR (Automatic Voltage Regulator) VL (Volt-Lock) Series.
- Cast iron sleeved engine for long durability with automatic low oil shutdown protection.
- Largest tank in the industry with extended run-time (less re-fueling) with integrated fuel gauge for convenience.
- Quiet muffler (Whisper Series) with USDA FS certified spark arrester.
- Conveniently located multi-featured control panel with FIRMAN custom designed outlet cover protecting outlets from dirt, dust and debris.
- 3 in 1 Data-Minder monitors running hours, voltage and frequency.
- Wheel Kit with heavy duty and over size flat free wheels with high leverage single folding handle with grip for easy maneuver.
- Durable compact roll-cage frame design with 1.2" steel tubing.
- Bonus accessories including engine oil, oil funnel and tool kit.
- Included battery for your convenience.
- 3 year warranty: best in industry.

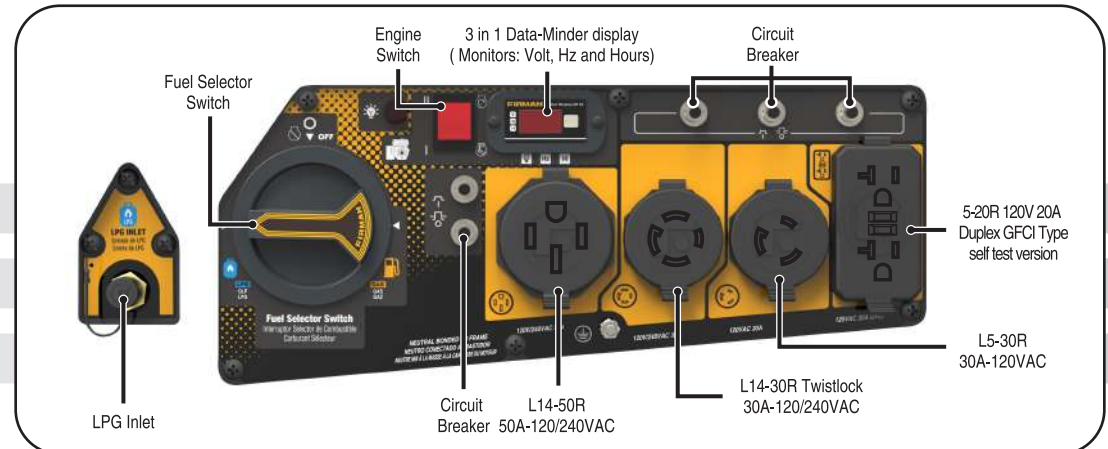



H08051

Hybrid Series



Specification

Model /Rev Level	P08051 / 00
UPC	840876180518
49 States	Yes
California (CARB)	Yes
Canada (CETL)	No
LPG Running Watts	7250
LPG Starting Watts	9050
GAS Running Watts	8000
GAS Starting Watts	10000
Frequency (Hz)	60
Engine Displacement (cc)	439
Engine Type	OHV
Starting System	Recoil/Electric
Cylinder	Single
Fuel Type	Gasoline/LPG
Low Oil Shutdown	Yes
Cast Iron Sleeve	Yes
Brushed or Brushless Alternator	Brushed
Automatic Voltage Regulator (AVR)	Yes
Fuel Tank Volume (Gal)	8.0
Fuel Gauge	Yes
Runtime @50% load (hours)	12.0
USDA FS Certified Spark Arrester	Yes



Handle	Single Folding
Wheel	10.0" Flat Free
Battery	Yes
Accessories	Wheel kit-Oil Bottle Funnel-Tool Kit
Warranty Residential / Commercial	3 years / 90 days
Carton LxWxH (inch)	32.1 x 22.2 x 24.4
Unit Weight (lbs)	212
Shipping Weight (lbs)	234

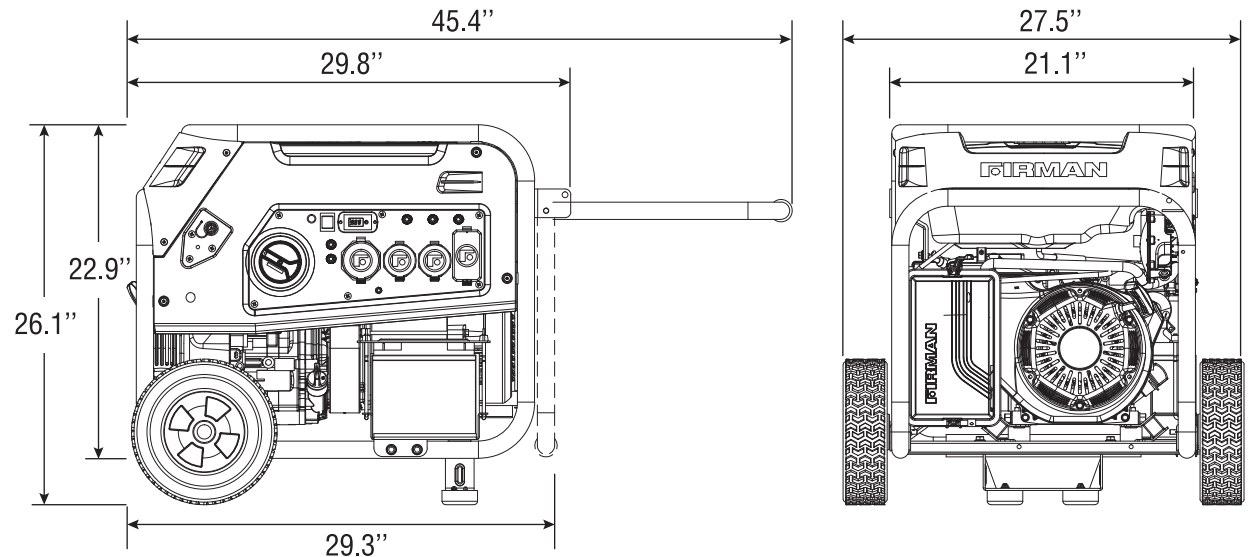

14131 N Rio Vista Blvd Suite 9
Peoria, AZ 85381

1-844-FIRMAN1 (1-844-347-6261)

www.firmangenerators.com