

### ENGINE SYSTEM

- Mitsubishi® L3E
- Diesel fueled
- EPA Tier 4 Final
- 3 cylinder
- 0.95 L displacement
- Power @ 1,800 rpm – HP (kW):
  - Prime: 11.3 (8.4)
  - Standby: 12.2 (9.1)
- Air filter: Dry type cartridge

### Fuel System

- Polyethylene tank – 39.9 gal (151.04 L) capacity
- Run time – 100% load: 67 hr\*
- Fuel consumption – 100% load: 0.59 gph (2.2 Lph)\*
- Fill port diameter: 3.5 in (89 mm)

### Cooling System

- Liquid cooled

### Lubrication System

- Oil filter: Full flow, spin-on type
- 1,000-hr service interval\*\*

*\*Data based on engine manufacturer and field test data after 100-hr engine break-in period. Actual results may vary, according to factors such as age and maintenance of equipment, environmental conditions, and fuel density. For fuel and maintenance recommendations, see owner's manual.*

*\*\*For maximum service interval, replace oil filter after 50-hr break-in period. For oil filter model number, see owner's manual.*

### GENERATOR

- 60 Hz engine/generator
- Marathon Electric® brushless
- Up to 6 kW output
- 120/240 VAC, 20/30 A
- ± 6% capacitor voltage regulation

### CONTROLS

- Illuminated control panel with sealed switches
- Key-activated switch with 4 positions (OFF, RUN, GLOW PLUG, START)
- One switch controls all light fixtures
- Digital hour meter
- Automatic shutdown for low oil pressure and high coolant temperature
- Wet-stacking mitigation



Picture shown may not reflect actual configuration.

## FLOODLIGHTS

- Four 296 W LED fixtures
- Aluminum and polymer housing
- Efficiency: 145 lpw
- Lm/fixture: 43,050
- Total lm: 172,200
- Coverage: 19,526 ft<sup>2</sup> (1,814 m<sup>2</sup>) @ 0.5 ft-c
- IP68 LED modules; IP65 rated drivers
- Fixture-mounted drivers

## ELECTRICAL SYSTEM

- 30 A start trip breaker (ensures no-load condition exists at start-up)
- Floodlight circuits with sealed 10 A breakers
- Convenience receptacles with individual breakers:
  - One 120 VAC, 20 A, GFCI, duplex outlet (NEMA 5-20R type)
  - One 240 VAC, 30 A, twistlock outlet (NEMA L6-30R type)
- Wiring is sized and fused to required amperage draw
- 440 CCA wet cell battery

## MAST

- Vertical operation and storage
- Five tubular steel sections with polymer guides
- Ground-adjustable light fixtures
- Winch: Dual handle, manual crank
- Distinctive angled fixture mount for common light distribution
- Rotation: 359° range of motion, adjustable from ground during full extension
- Industrial black powder-coat finish
- Self-retracting, coiled mast cord

## ENCLOSURE

- Hood:
  - Injection-molded with UV protected colorant
  - Flip-up design for ease of service
- Sound rating: 63 dB(A) at 23 ft (7 m) @ prime power
- Lifting point and fork pockets
- Multi-lingual operating and safety decals
- Illuminated license plate holder
- Document holder with owner's manual – includes AC and DC wiring diagrams

## TRAILER

- Tubular steel frame
- 2 in (50.8 mm) ball hitch
- Three 1,200 lb (544 kg) leveling jacks – lockable into stowed positions
- Folding tongue
- Side outriggers
- 7,800 lb (3,538 kg) safety chains with spring loaded safety hooks
- Transportation tie-downs
- DOT approved LED lights: Tail, side, brake, and directionals
- 2,200 lb (998 kg) leaf spring axle
- Tires: ST175/80D13, 6 ply

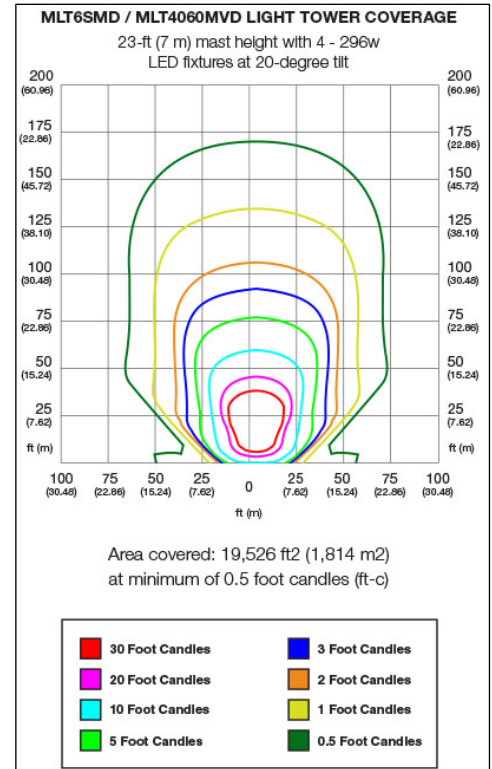

## OPTIONS

- Electric winch
- Winch cover
- Positive air shutdown
- Tandem tow
- Battery charger
- Batter disconnect
- Power Zone® controller
- Telemetry
- Lower radiator hose heater
- Fuel filter heater

## DIMENSIONS

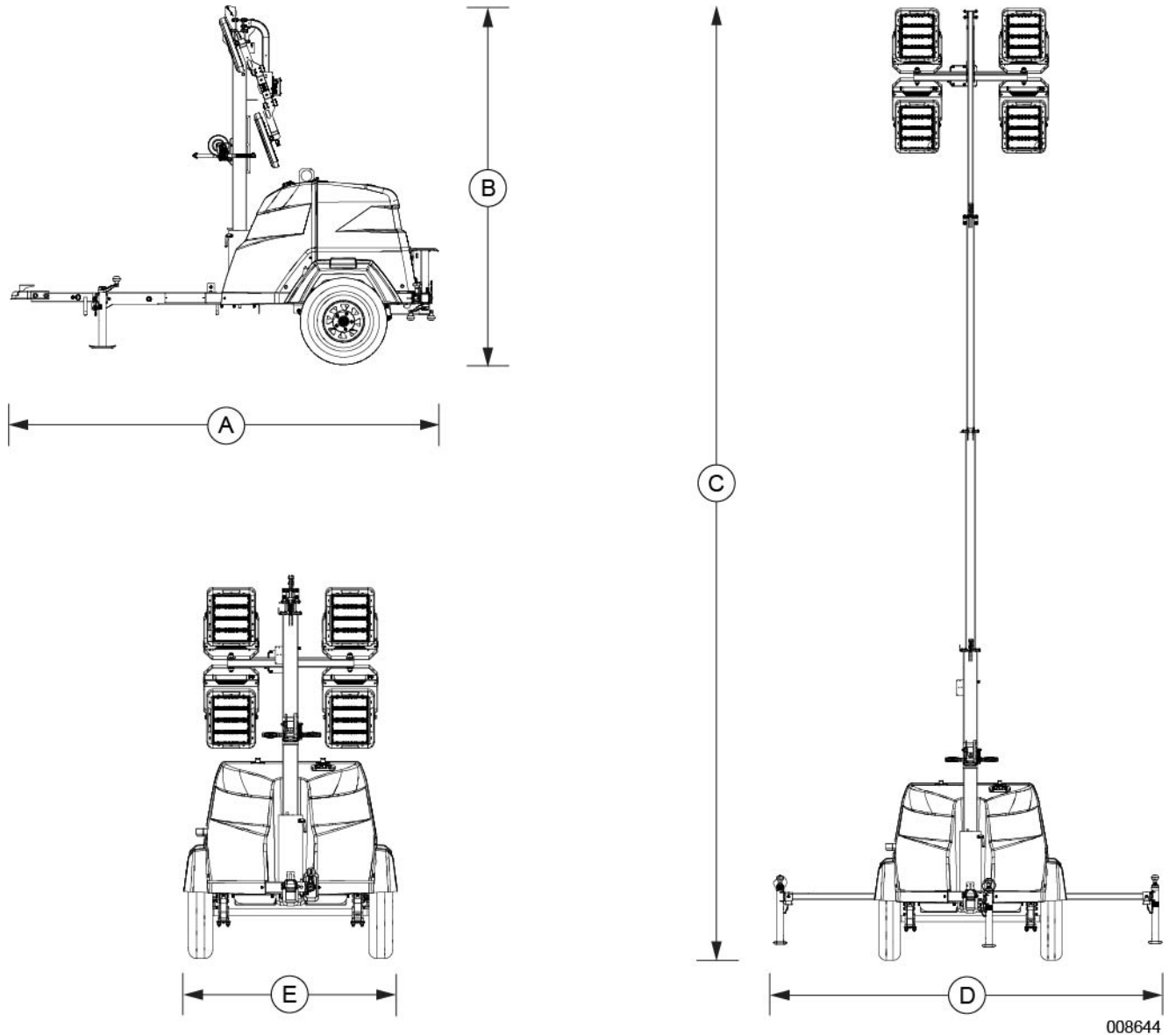

A	B	C	D	E
118 in (3 m)	101 in (2.6 m)	23 ft (7 m)	10 ft (3.05 m)	57 in (1.45 m)

## WEIGHT

- Dry: 1,310 lb (594 kg)
- Operating: 1,600 lb (726 kg)

**AMBIENT CLIMATE RATINGS**

- Maximum wind speed: 65 mph (105 km/h)
- Maximum air temperature – °F (°C):
  - Lights only: 120 (49)
  - 100% load: 104 (40)

**WARRANTY**

- Tower: 1 year, unlimited hours/2 years, 2,000 hours
- LED modules and drivers: 5 year limited warranty

**CERTIFICATIONS**

CSA approved, listed

**FOR MORE INFORMATION**

Owner's manual is available at [www.generacmobileproducts.com/service-support/manuals](http://www.generacmobileproducts.com/service-support/manuals).