



*Smart Management Module  
(SMM)  
Owner's/Installation Manual*

MODEL: 006873

DATE PURCHASED: \_\_\_\_\_

WWW.GENERAC.COM

888-436-3722

Para español , visita: <http://www.generac.com/service-support/product-support-lookup>

Pour le français, visiter : <http://www.generac.com/service-support/product-support-lookup>



**SAVE THIS MANUAL FOR FUTURE REFERENCE**

---

**⚠ WARNING**

California Proposition 65. Engine exhaust and some of its constituents are known to the state of California to cause cancer, birth defects, and other reproductive harm. (000004)

---

**⚠ WARNING**

California Proposition 65. This product contains or emits chemicals known to the state of California to cause cancer, birth defects, and other reproductive harm. (000005)

---

# Table of Contents

---

## ***Section 1 Introduction and Safety***

Introduction .....	1
Safety Rules .....	1
.....	1

## ***Section 2 General Information and Setup***

Know Your Smart Management Module and Carton Contents .....	3
Sequence of Operations .....	5

## ***Section 3 Installation, Tests and Troubleshooting***

Electrical Specifications .....	7
Enclosure Specifications .....	7
Remove Contents from Carton .....	7
Tools Needed For Installation .....	7
Mounting Instructions .....	7
Connections .....	8
Setting Priorities .....	8
Setting Lockout .....	8
Tests .....	8
Troubleshooting .....	9

**This page intentionally left blank.**

---

# Section 1 Introduction and Safety

## Introduction

Thank you for purchasing a Generac Smart Management Module. The Smart Management Modules (SMM) are designed to work together to prevent the home standby generator from being overloaded by large appliance loads. The modules require no control wires, and provide a cost effective, quick installation. Use of up to eight modules is available, allowing protection of your home and necessary appliances.

Read this manual thoroughly and understand all of the instructions, cautions, and warnings before using this equipment. If any section of the manual is not understood, contact your nearest authorized dealer, or contact Generac Customer Service at 1-888-436-3722, or [www.generac.com](http://www.generac.com) with any questions or concerns.

The owner is responsible for proper maintenance and safe use of the equipment. Before operating, servicing or storing this product:

- Study all warnings in this manual and on the product carefully.
- Become familiar with this manual and the product before use.
- Refer to the Installation section of the manual for instructions on final assembly procedures. Follow the instructions completely.

Save these instructions for future reference. ALWAYS supply this manual to any individual that will use this product.

THE INFORMATION CONTAINED HEREIN WAS BASED ON PRODUCTS IN PRODUCTION AT THE TIME OF PUBLICATION. GENERAC RESERVES THE RIGHT TO MODIFY THIS MANUAL AT ANY TIME.

## Safety Rules

The manufacturer cannot anticipate every possible circumstance that might involve a hazard. The warnings in this manual, and on tags and decals affixed to the unit are, therefore, not all inclusive. If using a procedure, work method or operating technique that the manufacturer does not specifically recommend, verify that it is safe for others. Also make sure the procedure, work method or operating technique utilized does not render the equipment unsafe.

Throughout this publication, DANGER, WARNING, CAUTION and NOTE blocks are used to alert personnel to special instructions about a particular operation that may be hazardous if performed incorrectly or carelessly. Observe them carefully. Their definitions are as follows:

---

### DANGER

Indicates a hazardous situation which, if not avoided, will result in death or serious injury.

(000001)

---

### WARNING

Indicates a hazardous situation which, if not avoided, could result in death or serious injury.

(000002)

---

### CAUTION

Indicates a hazardous situation which, if not avoided, could result in minor or moderate injury.

(000003)

---

### NOTE:

Notes contain additional information important to a procedure and will be found within the regular text of this manual.

These safety warnings cannot eliminate the hazards that they indicate. Common sense and strict compliance with the special instructions while performing the action or service are essential to preventing accidents.



### WARNING

Consult Manual. Read and understand manual completely before using product. Failure to completely understand manual and product could result in death or serious injury. (000100a)

---

**This page intentionally left blank.**

## Section 2 General Information and Setup

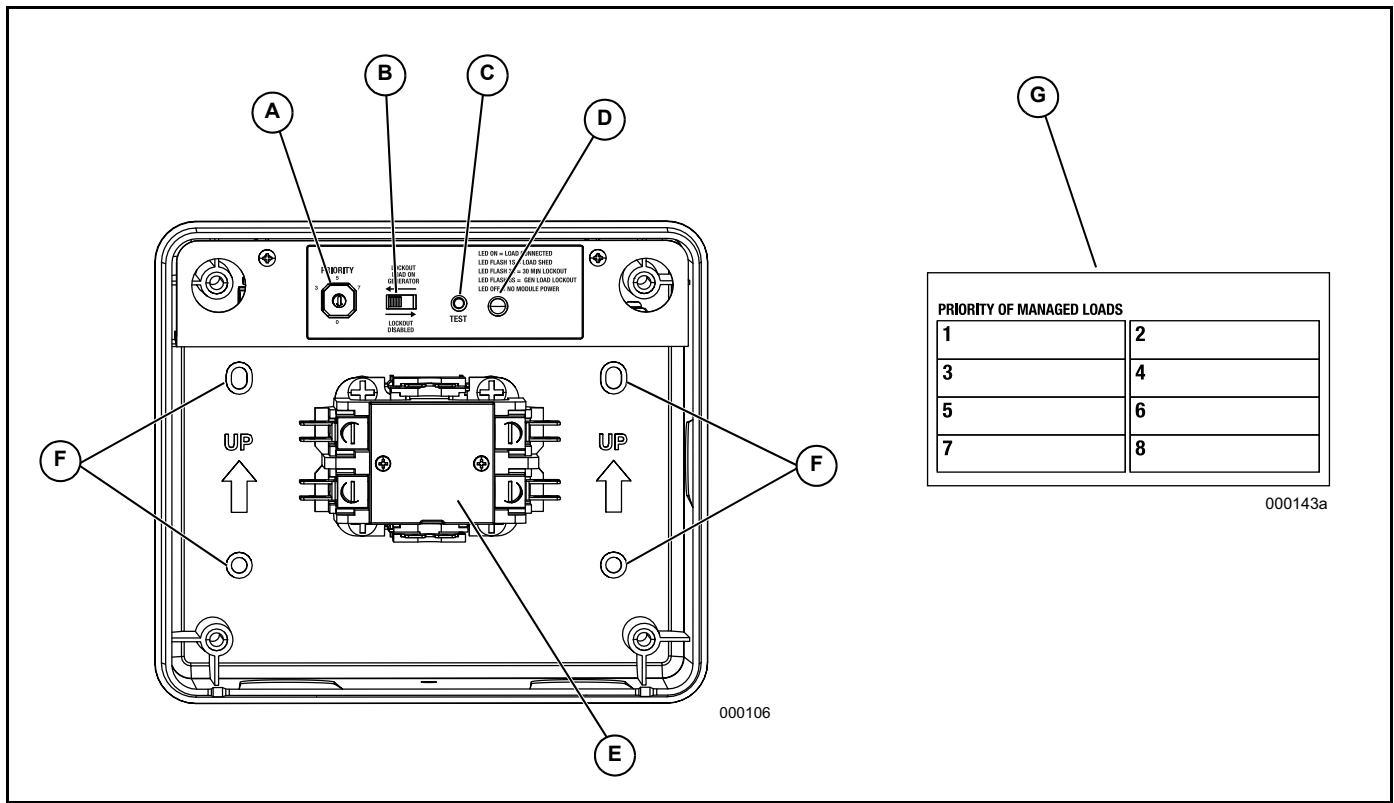

Figure 2-1. Features and Controls

### Know Your Smart Management Module and Carton Contents

**Priority Dial (A)** – Sets module priority.

**NOTE: PRIORITY MUST BE DIFFERENT for each module in an installation.** Priority sets the order in which loads recover from a load shed event. Recovery time from a load shed event is five minutes for Priority 1. Each priority after Priority 1 waits an additional 15 seconds after the initial recovery time. See Table 1.

**Lockout Switch (B)** – Prevents load from operating when system is operating under generator power. See Table 2.

**NOTE:** Recovery time is based on priority dial settings. See Table 1.

**Test Button (C)** – Disables contactor output for a specified time.

**LED (D)** – Provides module status. See Table 3.

**Contactor (E)** – Controlled by a smart controller in module. Contactor remains CLOSED until generator power is required. Upon generator activation, controller moves to OPEN to handle overload conditions.

**NOTE:** The contactor is also opened during lockout switch ACTIVE state.

**Mounting Holes (F)** – Internal enclosure mounting holes provide clean and sturdy mounting.

**Priority Decal (G)** – Provided for recording priority of each module in installation. Should be installed on electrical panel.

Table 1. Priority Dial Settings

Priority	Recovery Time
1	5 minutes
2	5 minutes 15 seconds
3	5 minutes 30 seconds
4	5 minutes 45 seconds
5	6 minutes
6	6 minutes 15 seconds
7	6 minutes 30 seconds
8	6 minutes 45 seconds
9	Not Used
0	Not Used

**Table 2. Lockout Switch Settings**

Lockout Switch Position	Mode	Function
ON	GENERATOR	Power is NOT available on module output (contactor output). Contactor is OPEN.
ON	UTILITY	Power is available on module output (contactor output). Contactor is CLOSED.
OFF	GENERATOR	Module operates with standard load shed logic. Contactor is OPEN or CLOSED per logic.
OFF	UTILITY	Power is available on module output (contactor output). Contactor is CLOSED.

**Table 3. LED States**

State	LED State	Mode	Note
Shed	1 second flash (1 On – 1 Off)	Generator	Module detected an overload and shed its load. This state only occurs in generator mode, or during a first time utility power up for five minutes of initial operation.
Lockout (30 minutes)	3 second flash (3 On – 3 Off)	Generator	Module detected an overload while trying to recover from a shed situation. It identified the offending load and disabled operation for 30 minutes to allow other loads to operate. This state only occurs in generator mode.
Lockout Switch Active	6 second flash (6 On – 6 Off)	Generator	Module output is disabled and there is no power to the appliance while in generator mode. Lockout switch must be ON. See Table 2.
Lockout Switch Active	ON	Utility	Lockout Switch operates in generator mode only. It has no function in utility mode. LED is solid, indicating contactor is CLOSED and load is connected. Lockout switch must be ON. See Table 2.
Normal	ON	Generator or Utility	Indicates contactor is CLOSED and appliance has power. This is the default in utility mode. It is the normal operating state in generator mode when an overload is not detected.
Test	1 second flash	Generator or Utility	Test button triggers a typical shed condition and overrides all other states except generator lockout switch ACTIVE state.





**This page intentionally left blank.**

# Section 3 Installation, Tests and Troubleshooting

## Electrical Specifications

Input Voltage	240 VAC
Current Rating	50A resistive, 40A inductive
Locked Rotor Amp Rating	240A
Motor Rating	3HP
Contactor Coil Voltage	240 VAC

## Enclosure Specifications

UL Rating	Type 3R
Temperature	-30 to 50 deg C (-22 to 122 deg F)

## Remove Contents from Carton

1. Open carton.
2. Remove and verify carton contents.
3. Retain carton for mounting template.

## Carton Contents:

- Smart Management Module (SMM)
  - Priority decal
  - Owner/Installation manual
4. Contact the place of purchase with the unit model number for any missing carton contents.
  5. Record date of purchase on front cover of this manual.

## Tools Needed For Installation

- Power drill and suitable drill bit
- Phillips and flat head screwdrivers
- Mounting screws or wall anchors
- Electrical materials

## Mounting Instructions

The recommended installation is near the electrical panel or appliance/load. The enclosure has a UL type 3R rating and can be mounted indoors or outdoors. It provides a degree of protection against rain and sleet and is undamaged by the formation of ice on the enclosure.



**⚠ DANGER**

Electrocution. Turn utility and emergency power supplies to OFF before connecting power source and load lines. Failure to do so will result in death or serious injury. (000116)

1. Turn OFF both UTILITY (NORMAL) and EMERGENCY (STANDBY) power supplies.
2. Choose mounting location (near electrical panel, appliance or load to be managed).
3. Use a flat head screwdriver to remove appropriate knockouts from module enclosure for wiring. See A in Figure 3-1.

**NOTE:** If outdoor installation is chosen, bottom knockouts must be used to meet NEMA 3R rating and protect against water ingress.

4. Hold SMM enclosure against mounting surface with arrows pointing up, and mark or drill four mounting holes. See B in Figure 3-1 for arrows.
5. Install SMM enclosure to mounting surface using appropriate mounting screws or wall anchors.

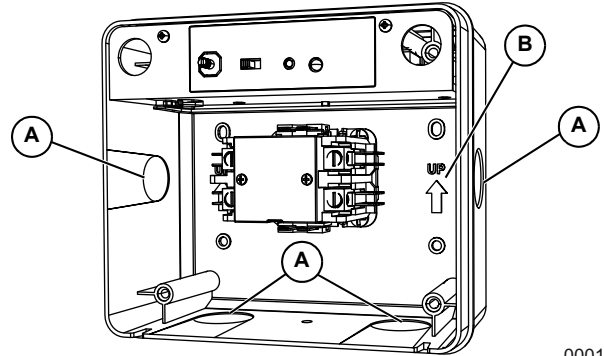

Figure 3-1. Knockouts and UP Arrows

000138

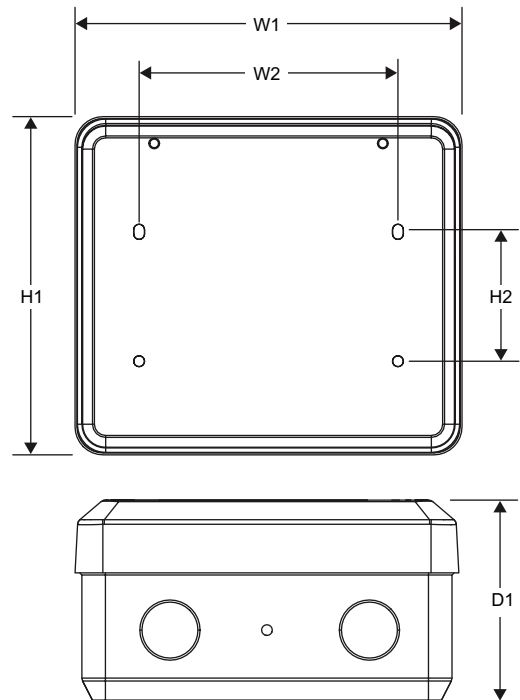

Figure 3-2. Mounting Dimensions

000107

Height (in/mm)	H1	6.17/156.8
	H2	2.36/60
Width (in/mm)	W1	7.06/179.4
	W2	4.72/120
Depth (in/mm)	D1	3.7/94

## Connections

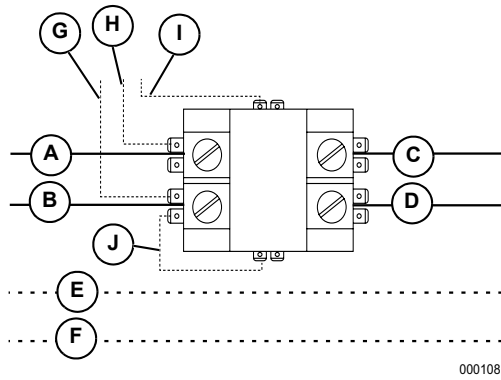

Figure 3-3. Wiring Diagram

Legend	
A	Red (240 VAC - Line)
B	Black (240 VAC - Line)
C	Red (240 VAC - Load)
D	Black (240 VAC - Load)
E	White - Neutral (as required)
F	Green - Ground (as required)
G	Black - Factory (PCB)
H	Red - Factory (PCB)
I	Blue - Factory (PCB)
J	Blue - Factory (Jumper)



### **⚠ DANGER**

Electrocution. Turn utility and emergency power supplies to OFF before connecting power source and load lines. Failure to do so will result in death or serious injury. (000116)

1. Turn OFF both UTILITY (NORMAL) and EMERGENCY (STANDBY) power supplies before connecting power source and load lines to transfer switch and SMM.

**NOTE:** Suitable conduit fittings must be installed in knockout openings when running supply and load wires.

**NOTE:** Use at least 75 °C rated wire and gauge per installation instructions. Refer to table for recommended wire size based on load current.

Temperature rating of conductor: 75 °C (167 °F)	
Conductor types (must be copper): RHW, THHW, THW, THWN, XHHW, USE, ZW	
Size AWG	Maximum Current Rating
14	20A
12	25A
10	35A
8	50A

2. Run line supply wires per applicable NEC code articles for wiring method selected.

3. Run load wires per applicable NEC code articles for wiring method selected.
4. Connect line supply wiring to line side of SMM contactor field terminals. See Figure 3-2. Tighten field terminals to **25 in-lbs** (2.8 Nm).
5. Connect load supply wiring to load side of SMM contactor field terminals. See Figure 3-2.

**NOTE:** If neutral and ground wires are included, connect inside SMM using a listed termination device.

The unit is now ready to apply power and perform testing.

## Setting Priorities

High priority 240 VAC loads should be set to the highest priorities so those loads recover first, in the event of generator overload.

**NOTE:** The highest priority, and first load to activate is Priority 1. The last load to activate is Priority 8.

Setting priority determines timing for 3 scenarios:

- Order in which loads recover
- Delay time until power returns during an outage
- Delay time for post load shed recovery

An example configuration is shown below. Configurations will vary depending on customer prioritization of loads:

- Priority 1 - Baseboard heat
- Priority 2 - Air conditioner
- Priority 3 - Range
- Priority 4 - Dryer
- Priority 5 - Non-essential circuits
- Priority 6 - Pool pump or hot tub
- Priority 7 - Other circuits
- Priority 8 - Other circuits

1. Set the priority of each SMM module as desired (using the example configuration for reference).
2. Apply priority decal in a suitable location on electrical panel to record chosen priority designations.
3. Record priorities on decal.

## Setting Lockout

Most installations will require the lockout switch will be DISABLED. When performing a whole house backup with a generator not sized to manage all household loads, SMM's can be used to disable appliances or circuits during an outage. For non-essential loads that will not be used on generator power, set lockout switch to ENABLED.

## Tests

### Utility Test

1. Turn utility power ON and enable all module feeding circuits.
2. Verify LED begins to flash at one second intervals.
3. All contactors will close after five minutes. LED will illuminate, and stay ON.
4. Wait 30 seconds after contactor closes, then press TEST button and verify module load shed. LED will flash at one second intervals.
5. Wait five minutes, plus predefined priority set time for module to recover.
6. Contactor will CLOSE and LED will illuminate, and stay ON.

### Generator Test

1. Simulate a utility loss by turning main line circuit breaker (MLCB - service disconnect) to OFF while generator is in AUTO.
2. All modules will lose power and LEDs will disable.
3. Generator will power on after preset delay.
4. All LEDs will flash when generator transfers.
5. Allow each module to enable output per its priority setting.
6. After predefined priority time elapses, each contactor will CLOSE and LED will illuminate and stay ON.
7. Once LED stays ON, press TEST button and verify load shed occurs.
8. Once load shed occurs, LED will flash at one second intervals.
9. Allow time for each module to enable contactor output per priority setting.
10. After predefined priority set time, each contactor will CLOSE and LED will illuminate and stay ON.

**NOTE:** Depending on load size, the SMM module may immediately go into load shed mode or lockout during test. In this event, remove one or more higher priority loads to allow testing of each module.

### Generator Test with Lockout Switch Enabled (perform if Lockout Switch Enabled on any loads)

1. Simulate a utility loss by turning MLCB (service disconnect) to OFF while generator is in AUTO.

2. All modules will lose power and LEDs will disable.
3. Generator should power on after preset delay.

**NOTE:** For modules with lockout switch enabled, LEDs will flash at six second intervals and load will remain disabled while in generator power.

### Return to Utility Test

1. Return utility power by setting the MLCB (service disconnect) to ON.

**NOTE:** All modules should begin flashing at one second intervals.

**NOTE:** All modules will recover in five minutes (including units with lockout switch enabled).

### Installation Summary

- Install cover on electrical panel.
- Install covers on modules.

### Troubleshooting

See Table 4 for troubleshooting problems, causes and corrections.

**Table 4. Troubleshooting**

Problem	Cause	Correction
Load not powered, LED is OFF	Circuit Breaker disabled.	Enable Circuit Breaker
Load not powered, LED is OFF	MLCB disabled and generator OFF.	Enable MLCB if utility is present or verify generator operation if outage.
Load not powered, LED flashing 1 second interval.	Generator power just applied to unit. Utility power just applied to unit. Generator was overloaded and shed occurred.	Wait 5 minutes plus the priority time delay (see Table 1) for unit to enable output.
Load not powered, LED flashing 3 second interval.	This load overloaded the generator while attempting recovery from a shed. It is in a 30 minute lockout wait period.	Wait 30 minutes from lockout for unit to attempt to re-apply load. Review all loads enabled in household. The generator may end up in another overload condition when this load is enabled. Disable some loads to prevent generator overload from recurring.
Load not powered, LED flashing 6 second interval.	The lockout switch is enabled and the unit is on generator power.	During installation, it was determined that this load will be disabled during generator operation to prevent generator overload. Contact servicing dealer for details.
SMM module is humming. <b>NOTE:</b> A normal 60 Hz hum is expected from the normally open contactor. Excessive hum may be caused by one of the following:	<ol style="list-style-type: none"> <li>1. Improper mounting.</li> <li>2. Contactor error or connections not correct.</li> </ol>	<ol style="list-style-type: none"> <li>1. Mount to wall or vertical surface with arrows pointing up only.</li> <li>2. Contact servicing dealer.</li> </ol>

**This page intentionally left blank.**



Part No. 0K7447 Rev. E 01/20/15 Printed in USA  
©2015 Generac Power Systems, Inc. All rights reserved  
Specifications are subject to change without notice.  
No reproduction allowed in any form without prior written  
consent from Generac Power Systems, Inc.

**GENERAC**<sup>®</sup>



Generac Power Systems, Inc.  
S45 W29290 Hwy. 59  
Waukesha, WI 53189  
1-888-GENERAC (1-888-436-3722)  
[generac.com](http://generac.com)