

PUMPS



5 YEAR LIMITED
AAA PUMP
WARRANTY

1 YEAR LIMITED
OEM TECHNOLOGIES
PUMP WARRANTY

OEM Technologies Pump Design

Vertical Axial Cam Pumps

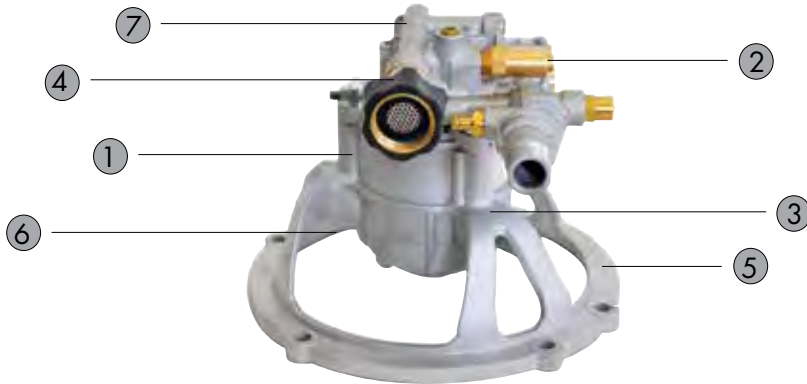

Vertical axial pump kits include a siphon tube with filter for chemical cleaning, mounting bolts and shaft key

Horizontal Axial Cam Pumps

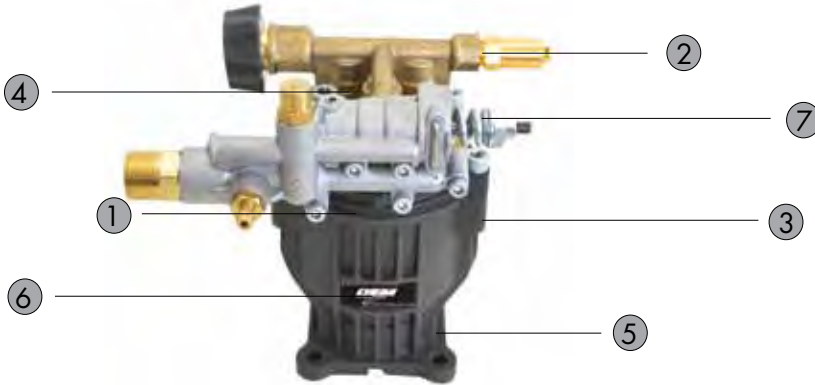

Horizontal axial pump kits include a siphon tube with filter for chemical cleaning, mounting bolts and shaft key

Features

- ① High performance double seal system prevents water leaks
- ② Thermal relief protection to prevent pump overheating
- ③ Dual oversized radial ball bearings are installed for better wear, friction resistance and precision polished stainless steel pistons for extended seal life
- ④ Sealed maintenance-free crankcase manufactured from fully anodized die cast aluminum for corrosion protection and is sealed to prevent contamination and lube failure.
- ⑤ Gas engine flange that fits most engines
- ⑥ Integrated unloader with easy start feature to make start up a breeze
- ⑦ Forged brass or aluminum head

AAA Pump Design

C30 Plunger Pumps

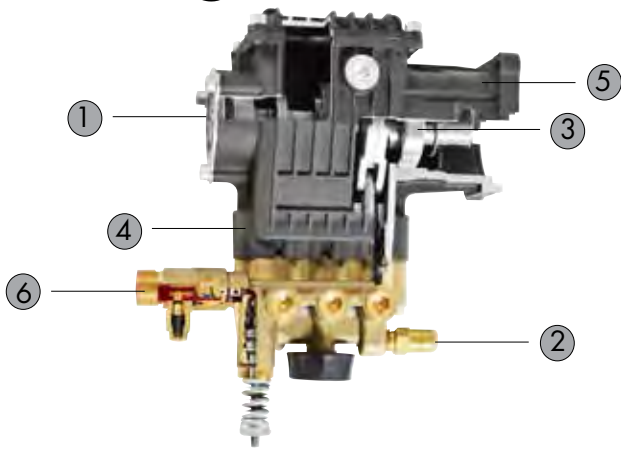

PowerBoost® Technology high pressure water flow in our C30 pump

C40 Plunger Pumps

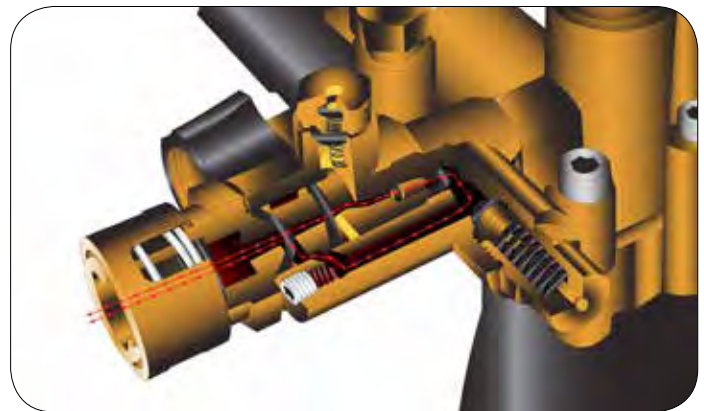
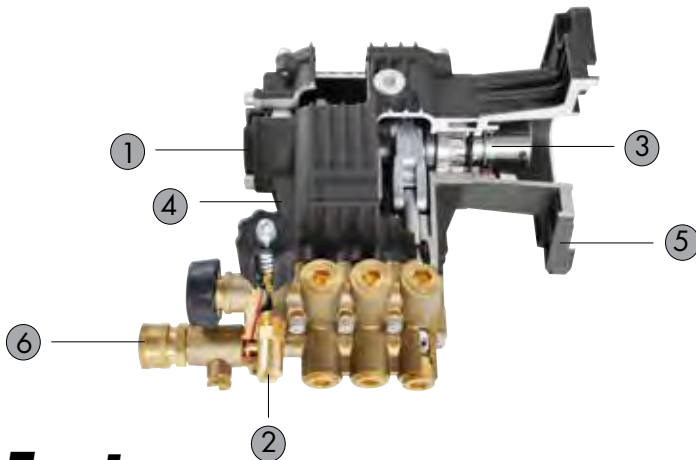

PowerBoost® Technology high pressure water flow in our C40 pump

Features

- 1 Oversized site glass and advanced oil seal technology does away with the need for a dipstick
- 2 Thermal relief protection to prevent pump overheating
- 3 Dual oversized radial ball bearings are installed for better wear, friction resistance and precision ceramic coated pistons for extended seal life
- 4 Crankcase is manufactured from fully anodized die cast aluminum for corrosion protection and is sealed to prevent contamination and lube failure
- 5 Gas engine flange and hollow shaft that fits most horizontal shaft engines.
- 6 Threaded M22 or quick connect outlet for easy connection to the pressure hose

PowerBoost® Technology

Patent pending PowerBoost® Technology Pump System is an innovation in pump technology that enhances real cleaning performance.

In a typical pump, as high pressure water travels from the pump head to the pump outlet a significant amount of pressure is lost due to the chemical suction feature. A pump with PowerBoost® technology operated in high pressure triggers a bypass around the venturi nozzle (chemical suction) to reduce this pressure loss.

Consequently, a PowerBoost® pump delivers higher pressure at the nozzle resulting in greater impact and cleaning performance than a typical pump using the same engine torque and horsepower configuration.

In addition to improved performance for better cleaning results, this revolutionary design reduces vibration, noise and heat to deliver a better working environment for the operator while extending engine and pump life.

AAA Pump Design

C31 Plunger Pumps

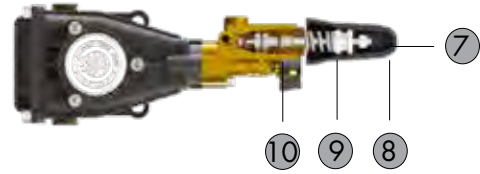

C41 Plunger Pumps

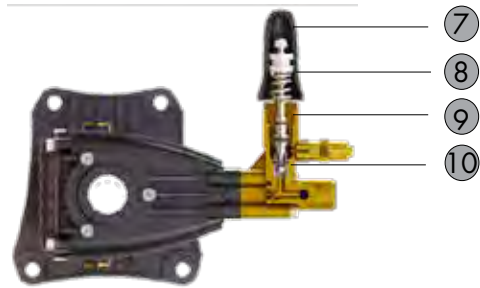

C45 Plunger Pumps

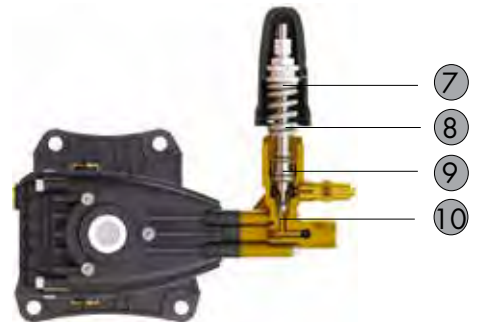

Features

- ① Site glass and advanced oil seal technology, does away with the need for a dipstick
- ② Thermal relief protection to prevent pump overheating
- ③ Dual oversized radial ball bearings are installed for better wear, friction resistance and precision ceramic coated pistons for extended seal life
- ④ Crankcase is manufactured from fully anodized die cast aluminum for corrosion protection and is sealed to prevent contamination and lube failure
- ⑤ Gas engine flange and hollow shaft that fits most horizontal shaft engines.
- ⑥ Threaded M22 or quick connect outlet for easy connection to the pressure hose

Unloader System

- ⑦ Fully adjustable unloader system with ergonomic control
- ⑧ Hi/Low accurate lock adjustment system
- ⑨ Anti-rotation pin
- ⑩ Superior alignment of moving parts

Pump Kit Specifications

OEM TECHNOLOGIES™ Vertical Axial

Model#	Part#	PSI	GPM	Kit Includes	Inlet port	Discharge Port	Inlet Pressure Range	Thermal Relief Port	Shaft Diameter	Flange Bolt Pattern	Key Way	Pump Oil Capacity	PowerBoost®	Head
90025	90025	2400	2.0	Siphon Mounting Bolts	3/4" GH	M22 Male	10-60 PSI	1/4" NPT	7/8"	SAE J-609D	3/16"	3.0 fl oz.	N	Aluminum
90026	90026	3000	2.4	Siphon Mounting Bolts	3/4" GH	M22 Male	10-60 PSI	1/4" NPT	7/8"	SAE J-609D	3/16"	3.0 fl oz.	N	Aluminum
90027	90027	3100	2.5	Siphon Mounting Bolts	3/4" GH	M22 Male	10-60 PSI	1/4" NPT	7/8"	SAE J-609D	3/16"	3.0 fl oz.	N	Brass

OEM TECHNOLOGIES™ Horizontal Axial

Model#	Part#	PSI	GPM	Kit Includes	Inlet port	Discharge Port	Inlet Pressure Range	Thermal Relief Port	Shaft Diameter	Flange Bolt Pattern	Key Way	Pump Oil Capacity	PowerBoost®	Head
90028	90028	3000	2.4	Siphon Mounting Bolts	3/4" GH	M22 Male	10-60 PSI	1/4" NPT	3/4"	SAE J-609A	3/16"	4.0 fl oz.	N	Aluminum
90029	90029	3100	2.5	Siphon Mounting Bolts	3/4" GH	M22 Male	10-60 PSI	1/4" NPT	3/4"	SAE J-609A	3/16"	4.0 fl oz.	Y	Brass

AAA™ Triplex

Model#	Part#	PSI	GPM	Kit Includes	Inlet port	Discharge Port	Inlet Pressure Range	Thermal Relief Port	Shaft Diameter	Flange Bolt Pattern	Key Way	Pump Oil Capacity	PowerBoost®	Head
90030	90030	3200	2.8	Siphon Mounting Bolts	3/4" GH	M22 Male	10-60 PSI	1/4" NPT	3/4"	SAE J-609A	3/16"	8.0 fl oz.	Y	Brass
90031	90031	3000	2.5	Siphon Mounting Bolts	3/4" GH	M22 Male	10-60 PSI	1/4" NPT	3/4"	SAE J-609A	3/16"	8.0 fl oz.	Y	Brass
90032	90032	3800	3.5	Siphon Mounting Bolts	3/4" GH	3/8" QC Female	10-60 PSI	1/2" NPT	24 mm	n/a	M8	11 fl oz.	Y	Brass
90033	90033	4000	3.3	Siphon Mounting Bolts	3/4" GH	3/8" QC Female	10-60 PSI	1/2" NPT	24 mm	n/a	M8	11 fl oz.	Y	Brass